

**2016 MAZDA3**



*Does Driving Matter?*

*Does a long, winding road or an empty freeway  
on Christmas morning matter if the car you're in  
doesn't take advantage of the moment?*

*Does safety, technology, efficiency or even beauty matter,  
if a car doesn't feel right in your hands?*

*If you build Mazdas, driving is what matters most.*

*That's why everything we do has one purpose...  
to make driving better.*

*Like creating safety technology that inspires confidence.*

*Engine technology that makes our cars and SUVs  
more fuel-efficient, responsive.  
And sticky in the turns.*

*With designs that capture motion,  
even when the car isn't moving.*

*What's better than a great driving car?*

*A car company that won't build anything less.*

**MAZDA. Driving Matters™**



**DRIVING ISN'T A JOB, ERRAND, ASSIGNMENT, OR CHORE. AMEN TO THAT.**

In the Mazda3, art meets engineering. But to what end? Do the incessantly improving specs matter most to you? Are you drawn to our determination to create sculptural perfection through our KODO: "Soul of Motion" design? Is it our focused desire to create a car that's light, strong and technologically spectacular? The truth is, Mazda knows that all of it matters. Because driving matters.

From the drawing board to the passing lane, driving is our final indicator of success. So how do you feel about driving? About feeling connected to your car and the road? About always being the first to volunteer when your friends want to head out for fun? That matters most of all. Because if you like driving, you may find yourself loving the Mazda3.



Mazda3 s Grand Touring 5-Door model shown in Soul Red Metallic

A 2015 *Car and Driver* 10Best

2015 *Car and Driver* Editors' Choice Award –  
Compact Car

**TO ENGINEER A CAR FOR DRIVERS, IT HELPS TO LOVE DRIVING.**

Versatile. Nimble. Striking. The Mazda3 is all of these things. Built by design perfectionists for driving enthusiasts, the Mazda3 has been crafted inside and out with premium design sensibilities and precision engineering. It feels poised and looks as if in motion, even before you start the engine. And the Mazda3 offers more advanced safety innovations than any other car in its class.<sup>1</sup> It's loaded with available high-end features and next-generation

innovations, along with the Mazda3's legendary driving dynamics. Better than ever and as versatile as always, the Mazda3 proves that one car can offer everything you need to love driving even more—in an affordable, fun-to-drive package.



## OUR MOST TECHNOLOGICALLY ADVANCED MAZDA3 YET.

The Mazda3 never stops pushing the limits of innovation and design. From its excellent fuel efficiency and cutting-edge technologies to its premium available features and head-turning design, the Mazda3 truly offers more, settling for nothing less than the best driving experience possible. The details will always matter to us because driving matters to you.

### THE LIST OF NUMEROUS STANDARD AND AVAILABLE ADVANCED FEATURES AND INNOVATIONS GOES ON AND ON.

4-Wheel disc brakes	Forward Obstruction Warning <sup>3</sup>	SKYACTIV <sup>®</sup> -Drive automatic transmission
Anti-lock Brake System	High Beam Control	SKYACTIV <sup>®</sup> -Body
Electronic Brakeforce Distribution	Lane Departure Warning System <sup>3</sup>	SKYACTIV <sup>®</sup> -Chassis
Brake Assist	Smart City Brake Support <sup>4</sup>	i-ELOOP regenerative engine braking system
Six standard air bags <sup>1</sup>	Mazda Radar Cruise Control <sup>3</sup>	Up to 60 percent ultra-high and high tensile steel
Blind Spot Monitoring <sup>2</sup>	SKYACTIV <sup>®</sup> -G 2.0L and 2.5L gasoline engines	
Rear Cross Traffic Alert <sup>2</sup>	SKYACTIV <sup>®</sup> -MT manual transmission	

UP TO AN EPA-ESTIMATED  
**40** HWY  
 MPG<sup>8</sup>  
 5-DOOR



Bluetooth <sup>®</sup> hands-free phone and audio streaming	MAZDA CONNECT <sup>™</sup> infotainment system <sup>6</sup> with:
Bose <sup>®</sup> Centerpoint <sup>®</sup> 2 Surround Sound System with 9 speakers	- 7-inch full-color touch-screen display
CD/MP3 player	- Multifunction Commander control
SiriusXM Satellite Radio <sup>5</sup>	- Infotainment system voice command
Mazda Navigation System	- HD Radio <sup>™</sup>
	- Pandora <sup>®</sup> internet radio integration
	- Stitcher <sup>™</sup> internet radio integration
	- Stream Facebook and Twitter audio feeds via Aha <sup>™</sup> internet radio integration
	- SMS text message audio delivery and reply

Active Driving Display
Auto-dimming rearview mirror with HomeLink <sup>®</sup>
60/40 split fold-down rear seatbacks
Dual-stitched perforated leather-trimmed seats
Push Button Start

18-inch aluminum alloy wheels
4-wheel independent suspension
Active Grille Shutters
Mazda Advanced Keyless Entry System
Rain-sensing windshield wipers
Rearview camera <sup>7</sup>
Up to 47.1 cubic feet of cargo space (5-Door models)

Up to an EPA-est. 41 highway MPG <sup>9</sup>
Soul Red Metallic paint
KODO: "Soul of Motion" design
Adaptive Front-lighting System
Auto on/off headlights
Bi-Xenon headlights
LED daytime running lights
LED combination taillights

<sup>1</sup>Always wear your seat belt and secure children in the rear seat in appropriate child restraints. <sup>2</sup>Always check your mirrors. Be aware of the traffic around you. <sup>3</sup>Forward Obstruction Warning, Lane Departure Warning, and Mazda Radar Cruise Control are not substitutes for safe and attentive driving. There are limitations to the range and detection of the systems. Please see your owner's manual for further details. <sup>4</sup>Smart City Brake Support operates under certain low-speed conditions between about 2 and 18 mph. It is not a substitute for safe and attentive driving. Factors including movement and shape of the object in front of the vehicle, weather and road conditions can all impact automatic stopping. <sup>5</sup>SiriusXM Satellite Radio reception requires a subscription and Mazda satellite radio. See full disclaimer in Specifications. <sup>6</sup>Don't drive while distracted. Even with voice commands, only use MAZDA CONNECT<sup>™</sup>/ other devices when safe. Some features may be locked out while the vehicle is in gear. Not all features are compatible with all phones. Message and data rates may apply. <sup>7</sup>Rearview camera does not provide a comprehensive view of the entire rear area of this vehicle. Always check your surroundings. <sup>8</sup>Based on EPA estimates for 2016 Mazda3/5-Door models with 2.0L engine and automatic transmission 30 city/40 highway MPG. Mazda3 s Grand Touring 5-Door model with 2.5L engine and automatic transmission shown, EPA-estimated 27 city / 37 highway MPG. Actual results will vary. <sup>9</sup>Based on EPA estimates for 2016 Mazda3 / 4-Door models with 2.0L engine and automatic transmission 30 city/41 highway MPG. Actual results will vary.

Mazda3 s Grand Touring 5-Door model shown in Snowflake White Pearl Mica

## A REFLECTION ON PASSIONATE ENGINEERING.

The Mazda3 is a testament to obsessive engineering down to the smallest detail. To achieve a greater level of precision and artistry, Mazda engineers sculpt every design in hard clay rather than rely solely on computer-aided design. By using special tools crafted by the artists themselves, Mazda is able to produce a design so precise that it measures within a fraction of a millimeter of the engineers' original vision. Of course, the original vision was not to build to a set of mathematical equations. It was to create a sense of motion in every shape and detail. It's a level of craftsmanship that might seem extreme, but we're Mazda, and we won't build anything less.



### ENLIGHTENED DESIGN

Working in concert with the craftsmanship and artistry of clay modeling, our engineers used computer-aided drafting models to project simulated reflections on the surface of the Mazda3. Based on these reflections, our engineers subtly adjusted the lines and curves of the Mazda3's exterior design to achieve the most symmetrical and visually pleasing design.

## CAN HOW A CAR LOOKS IMPACT HOW IT FEELS TO DRIVE?

Every muscular line and refined curve of the Mazda3 embodies the most dramatic expression of KODO design. Slightly lower and wider than the previous generation, the Mazda3's crouching stance, prominent grille and piercing headlamps make a formidable first impression. But more than just being beautiful, the Mazda3 was designed with a focus on aerodynamics to

provide a very low coefficient of drag. A fancy way of saying that better aerodynamics equals improved gas mileage, performance and handling. We don't do it for bragging rights. We do it solely to elevate your driving experience.



### THE BIRTH OF SOUL

To create Soul Red Metallic, we put an innovative three-coat painting process into action. By using two separate coats of high-brightness aluminum flakes and high-chroma red pigment, we created a deep and vivid color that's unlike any other red on the road.

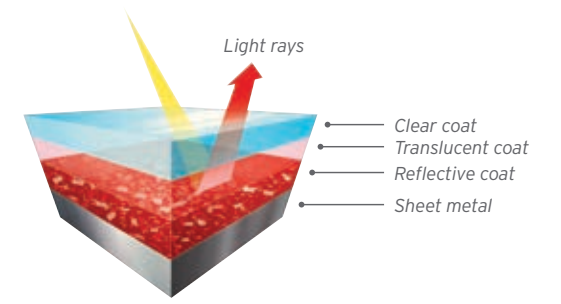

KODO: "Soul of Motion." Energy in motion. Power in motion. It's the inspiration behind the design of every Mazda vehicle. Created to transform ordinary sheet metal into something that embodies the vitality of a living being, KODO exudes the power and elegance of a wild animal in the instant before it pounces on its prey.

魂動

KODO : SOUL OF MOTION

Mazda3 s Grand Touring 5-Door model shown in Soul Red Metallic

## A CLEAR VISION OF THE ROAD AHEAD.

The Mazda3's KODO-design headlamps are not only striking, but provide a sharper vision of the road. Available Bi-Xenon headlights incorporate a dynamic light-guiding ring and feature LED Daytime Running Lights for more effective illumination. In s Grand Touring models, an Adaptive Front-lighting System helps you better see the curves of the road, while available

High Beam Control also improves your view. This innovative system works automatically to maximize your opportunity to use your high beams and, on the flip side, dim your lights when it detects approaching vehicles or vehicles in front of you in your lane. Beautifully designed and technologically advanced, there's no better way to illuminate your journey.



### FREE-FLOWING

Even the design of the Mazda3's grille improves gas mileage. The Mazda3 s Grand Touring with Technology Package is equipped with an Active Grille Shutter System that temporarily closes the grille shutters to limit excess airflow to the engine bay, improving aerodynamics.

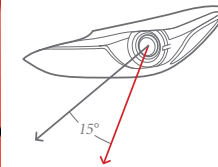
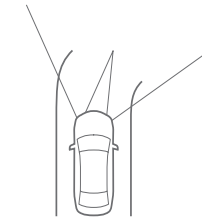

### BENDING LIGHT

Standard on s Grand Touring models, the Adaptive Front-lighting System automatically adjusts the angle of the vehicle's headlights according to the steering angle and vehicle speed. When cornering or approaching intersections at night, the headlights' beams illuminate the path the car will actually follow, thereby enhancing driver safety.





# SKYACTIV<sup>®</sup> TECHNOLOGY

AT MAZDA, EFFICIENCY IS AT THE HEART OF PERFORMANCE.

While other car companies compromise power to improve fuel efficiency, Mazda has taken a dramatically different approach. Far more than just an engine with hybrid-like efficiency, SKYACTIV TECHNOLOGY is a holistic system that takes the entire car into consideration, delivering a series of innovations that work together to improve the overall driving experience. Power and performance are delivered in abundance, along with efficiencies that allow the Mazda3 to offer up to an astounding EPA-estimated 41 highway MPG.<sup>1</sup>



## 01 SKYACTIV-G

By reimagining the combustion engine with a lofty compression ratio of 13:1, increased power no longer requires fuel-consuming engine displacement. Get up to an EPA-estimated 41 highway MPG<sup>1</sup> on 4-Door models and up to an EPA-estimated 40 highway MPG<sup>2</sup> on 5-Door models.

## 02A SKYACTIV-DRIVE

Our engineers created a new kind of precise, high-performance automatic transmission that combines the direct feel of a manual transmission with the silky smoothness of an automatic. In s models, Sport Mode provides a more performance-oriented shift logic, allowing you to hold lower gears longer and giving you more control when driving in challenging conditions, such as on curvy mountain roads.

## 02B SKYACTIV-MT

The Mazda3's six-speed manual transmission has a short shift throw inspired by the legendary Mazda MX-5 Miata. This generation's manual transmission is also smaller, lighter and stronger than any we've built before.

## 03 SKYACTIV-CHASSIS

The Mazda3's steering and suspension systems achieve two seemingly contradictory goals at once: to be nimble at low speeds, yet stable at high speeds. We also engineered them to be light, allowing for a more direct and agile feel.

## 04 SKYACTIV-BODY

Mazda was the first automaker to use ultra-high tensile-strength steel in a production vehicle. The SKYACTIV-Body in the Mazda3 continues to incorporate this light-but-strong steel in critical areas to help make it lighter than normal, yet stiffer and stronger.

## 05 i-ELOOP

i-ELOOP, Mazda3's available regenerative engine braking system, converts unused energy captured when the accelerator is released into electricity. This allows the car to use all its power during acceleration by eliminating alternator drag—for fuel savings of as much as 5 percent.<sup>3</sup>

<sup>1</sup>Based on EPA estimates for 2016 Mazda3 i 4-Door models with 2.0L engine and automatic transmission 30 city/41 highway MPG. Actual results will vary. <sup>2</sup>Based on EPA estimates for 2016 Mazda3 i 5-Door models with 2.0L engine and automatic transmission 30 city/40 highway MPG. Actual results will vary. <sup>3</sup>Actual results will vary based on driving conditions.





## **MORE INNOVATION. MORE DRIVING EXHILARATION.**

Exhilaration has always run in the Mazda3 family. And the 2016 Mazda3 continues this legacy. The Mazda3's already excellent performance and handling amplifies the exhilaration with a precisely tuned 4-wheel independent suspension system and your choice of spirited 2.0-liter or 2.5-liter SKYACTIV-G gasoline engines, with the 2.5-liter offering 184 horsepower. Also helping to make your drive nimble and responsive is the

Mazda3's Electric Power Assist Steering that allows you to feel the road, while Dynamic Stability Control<sup>1</sup> helps your wheels grip the road during quick turns. Precise, powerful and performance-oriented, the Mazda3 proves that more than ever, passion and performance are in its blood.

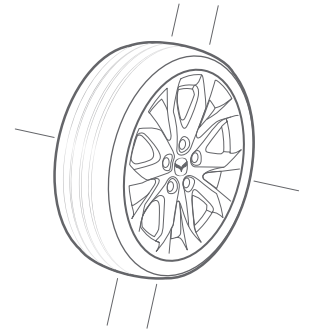

### **THE WHEEL REINVENTED**

Even at a standstill, the dynamic twists and turns in the Mazda3's wheel spokes give them the look of speed in motion. But beyond their athletic, high-end appearance, the available 18-inch aluminum alloy wheels are specially designed to suppress road noise and heighten handling stability.

Mazda3 s Grand Touring 4-Door model shown in Titanium Flash Mica

<sup>1</sup>Dynamic Stability Control (DSC) is an electronic system designed to help the driver maintain control under adverse conditions. It is not a substitute for safe driving practices. Factors including speed, road conditions and driver steering input can all affect whether DSC will be effective in preventing loss of control. Please see your owner's manual for further details.

## DRIVING WITH CONFIDENCE MATTERS.

**i-ACTIVSENSE**

You don't necessarily expect safety innovations to improve the driving experience. Unless you're a driving-obsessed automaker like Mazda. For the Mazda3, our engineers insisted on offering our full suite of i-ACTIVSENSE safety innovations—an available collection of advanced safety technologies not offered in any other car in its class<sup>1</sup>. An active approach to safety, i-ACTIVSENSE is designed to put you closely in tune with your surroundings. This is based on the belief that by making you more aware of road conditions, you'll be more relaxed and better prepared to help prevent an accident or lessen its severity.

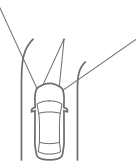

### 1 BI-XENON HEADLIGHTS WITH ADAPTIVE FRONT-LIGHTING SYSTEM

The Mazda3 offers available Bi-Xenon headlights with an Adaptive Front-lighting System. Designed to help you see around corners at night—literally. As you turn into a corner, the headlights pivot up to 15 degrees in the direction of your turn, improving visibility and allowing you to spot potential hazards and dangers ahead.



### 2 HIGH BEAM CONTROL

High Beam Control helps the driver see better at night by maximizing opportunities to use the high beams. The system automatically switches to the low beams when it detects oncoming traffic and/or a vehicle ahead.

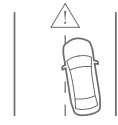

### 3 LANE DEPARTURE WARNING SYSTEM<sup>2</sup>

This system gives audible and visual warnings when the vehicle is about to unintentionally depart from its lane at a speed of 44 mph or higher.

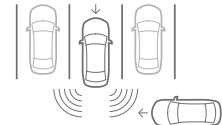

### 4 REAR CROSS TRAFFIC ALERT<sup>3</sup>

When backing out, this system detects a vehicle approaching from the side and promptly alerts the driver with an audible warning, as well as a visual warning in the passenger and driver's-side mirrors.

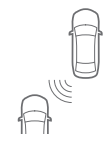

### 5 BLIND SPOT MONITORING<sup>3</sup>

Radar sensors detect objects in your left or right blind spots and then alert you with a warning light that appears in the corresponding side mirror. If you signal a lane change while an object is there, the light blinks and a cabin warning chime sounds.



### 6 SMART CITY BRAKE SUPPORT<sup>4</sup>

When travelling at speeds between about 2 and 18 mph, this intuitive system detects objects ahead and prepares the vehicle to stop by adjusting the brake pads closer to the disc. If no driver action is taken, the system automatically applies the brakes.



### 7 FORWARD OBSTRUCTION WARNING<sup>2</sup>

This system detects slower or stopped vehicles in front of the Mazda3 and gives an alert for the driver to brake or take evasive action, helping to reduce the risk of a potential collision.



### 8 MAZDA RADAR CRUISE CONTROL<sup>2</sup>

This system judges the relative speed and distance to the car ahead, and works within a set speed range to help maintain a safe following distance, making highway drives less strenuous.

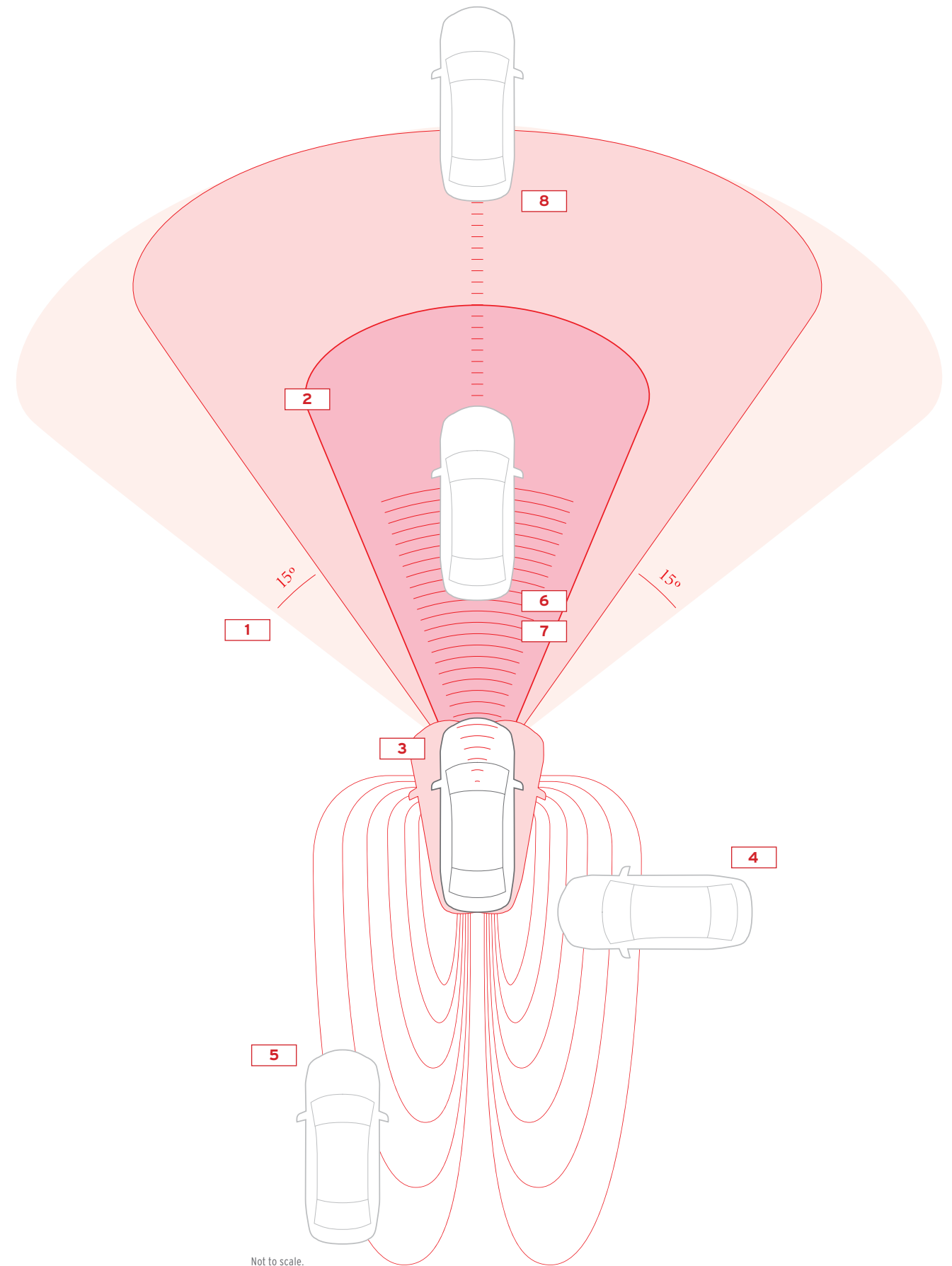

Not to scale.

<sup>1</sup>Based on comparison of non-luxury compact vehicles as categorized by *Automotive News*, 2013. <sup>2</sup>Lane Departure Warning, Mazda Radar Cruise Control and Forward Obstruction Warning are not substitutes for safe and attentive driving. There are limitations to the range and detection of the systems. Please see your owner's manual for further details. <sup>3</sup>Always check your mirrors. Be aware of the traffic around you. <sup>4</sup>Smart City Brake Support operates under certain low-speed conditions between about 2 and 18 mph. It is not a substitute for safe and attentive driving. Factors including movement and shape of the object in front of the vehicle, weather and road conditions can all impact automatic stopping.



## WHY MAZDA3 DRIVERS NEVER FEEL LIKE THEY'RE STUCK IN TRAFFIC.

For our Mazda engineers, creating a car that's sporty, practical and exhilarating to drive simply wasn't enough. They wanted to enliven the driving experience from the moment you open the door. To create this new level of connectedness, the center gauge lights up and pulsates like a heartbeat when you enter the cabin. And when you use the push button to start the ignition, the side gauges also illuminate, while the available Active Driving Display rises to greet you. Even the Mazda3 cockpit is built to keep you connected. Designed around a theoretical vanishing point that's forward-focused, it helps keep your attention on the road ahead. Just another reason why everything about the Mazda3 is exciting, alive—and completely connected.



### DASH YOUR INHIBITIONS

The available Active Driving Display helps you take your mind off distractions by projecting critical driving information directly in front of you, right within your line of sight. Strategically positioned directly in the driver's field of view and above the gauge cluster, this innovative display allows you to process information faster by keeping your eyes focused toward one place—the road ahead.

Information displayed: vehicle speed, navigational directions, safety alerts and cruise-control data



### TAKE CONTROL

Conveniently located on your steering wheel, paddle shifters (standard on s models with automatic transmission) allow you to upshift and downshift without taking your hands off the wheel. Or your eyes off the road.



Mazda3 s Grand Touring 4-Door interior shown in Almond leather

#### THE HOLE TRUTH

By making the seat perforations moderately large and the distances between them small, our engineers created upholstery that's not only soft and breathable, but also absorbs road noise for an enhanced audio listening environment.

#### PERFECT FIT

The Mazda3's sport seats are contoured to mold perfectly to the body, giving you and your passengers a more comfortable and connected ride, no matter how long the commute. Adding to the Mazda3's high-end appeal are its available dual-stitched leather and leatherette seats that are as carefully crafted as they are beautiful.

#### THE LITTLE THINGS WILL ALWAYS MATTER TO US.

The Mazda3's interior appointments offer a level of distinction that doesn't exist in comparable affordable compact cars. We used high-end materials and refined surface treatments such as the satin chrome finish on the climate control knobs and the new carbon fiber-look meter hood. The streamlined dash design and instrument panel give the driver and front passenger

better visibility and a feeling of spaciousness. And even the back passenger area feels like a top priority, offering generous leg room and more overall interior spaciousness than the Ford Focus, Honda Civic and Hyundai Elantra.



BLUETOOTH®  
HANDS-FREE  
PHONE



SMS TEXT  
READ OUT



STEP-BY-STEP  
AUDIO  
DIRECTIONS



3D INTERACTIVE  
MAP

### NAVIGATE

Our convenient available factory-integrated Mazda Navigation System offers the advanced features of today's navigation devices, including voice commands and advanced lane guidance. Plus, getting around town—or out of town—has never been easier thanks to the system's 3D interactive map with step-by-step audio directions.

### COMMUNICATE

With voice commands, making and receiving calls is as easy as pushing a button and saying hello. Thanks to the Mazda3's Bluetooth® hands-free phone and audio streaming, you stay entertained with streaming audio from your compatible mobile device. And SMS Text Message Audio Delivery and Reply lets you enjoy fully integrated display and audible readout of incoming text messages, and the ability to reply by choosing from a number of preset, standardized return messages.

BLUETOOTH®  
AUDIO-STREAMING



STITCHER™  
RADIO

PANDORA®  
RADIO

### ENTERTAIN

Of course AM/FM radio is always a choice, but now there are new ways to explore music and infotainment options via your Bluetooth®-enabled and Internet-connected device. Connect to your Facebook and Twitter feeds, enjoy HD Radio, listen to your own playlist or choose something from the integrated internet radio apps such as Pandora®, Aha™ and Stitcher.™

HD RADIO™

AHA™ RADIO

## WHEN YOU'RE CONNECTED, ALL YOU HAVE TO THINK ABOUT IS DRIVING.

Our most technologically advanced Mazda is equipped with our most technologically advanced cockpit. With MAZDA CONNECT™, our next-generation infotainment system,<sup>1</sup> you get a host of entertainment and information options. All you have to do is pair your smartphone with the Mazda3 via Bluetooth® to stream content from popular social media, music and infotainment apps such as Pandora®, Aha™ and Stitcher.™ Control the system and view information on your 7-inch full-color touch-screen display. Also enjoy access to standard USB audio input ports and an available factory-integrated Navigation System with cutting-edge features such as voice command and advanced lane guidance. And even with all these options, we still help you keep your eyes on the road. All the functions displayed on your touch screen can also be operated with the multifunction Commander control, conveniently located at your fingertips on the center console. All you have to focus on is driving—which is just how you like it.



PANDORA®

HD Radio®



aha.

STITCHER™  
RADIO ON DEMAND



### TAKE COMMAND

The multifunction Commander control positioned on the center console offers a seamless way to control the functions displayed on the available full-color touch-screen monitor—such as audio, hands-free telephone, and the available Navigation System.

<sup>1</sup>Don't drive while distracted. Even with voice commands, only use MAZDA CONNECT™ / other devices when safe. Some features may be locked out while the vehicle is in gear. Not all features are compatible with all phones. Message and data rates may apply.

*IN TUNE WITH YOU IN EVERY SENSE.*

We believe a connected driving experience should even include your sense of hearing. That's why for the Mazda3, we opted for nothing less than the latest generation Bose® Centerpoint® 2 Surround Sound System. This available system with 9 speakers enables listeners to enjoy a surround sound experience from nearly any stereo source, including CDs, MP3 devices, radio broadcasts and available SiriusXM Satellite Radio! It has been specifically engineered to meet the unique demands

of reproducing surround sound for the Mazda3's interior dimensions. And unlike conventional synthesized surround sound systems that compare left and right channel information to create a virtual surround experience, Centerpoint® 2 technology uses frequency content in addition to the stereo information to create a more lifelike surround experience, while AudioPilot® 2 technology compensates for ambient noise within the cabin.



**SPEAKERS:**

- A** 2.5-inch mid-range Twiddler® x 2   **B** Front-door 9-inch woofer x 2   **C** Front 3.25-inch mid-range center Twiddler® x 1  
**D** Rear-door 5.25-inch woofer x 2   **E** 2.5-inch mid-range Twiddler® x 2   **F** 5200-series, 8-channel digital amplifier

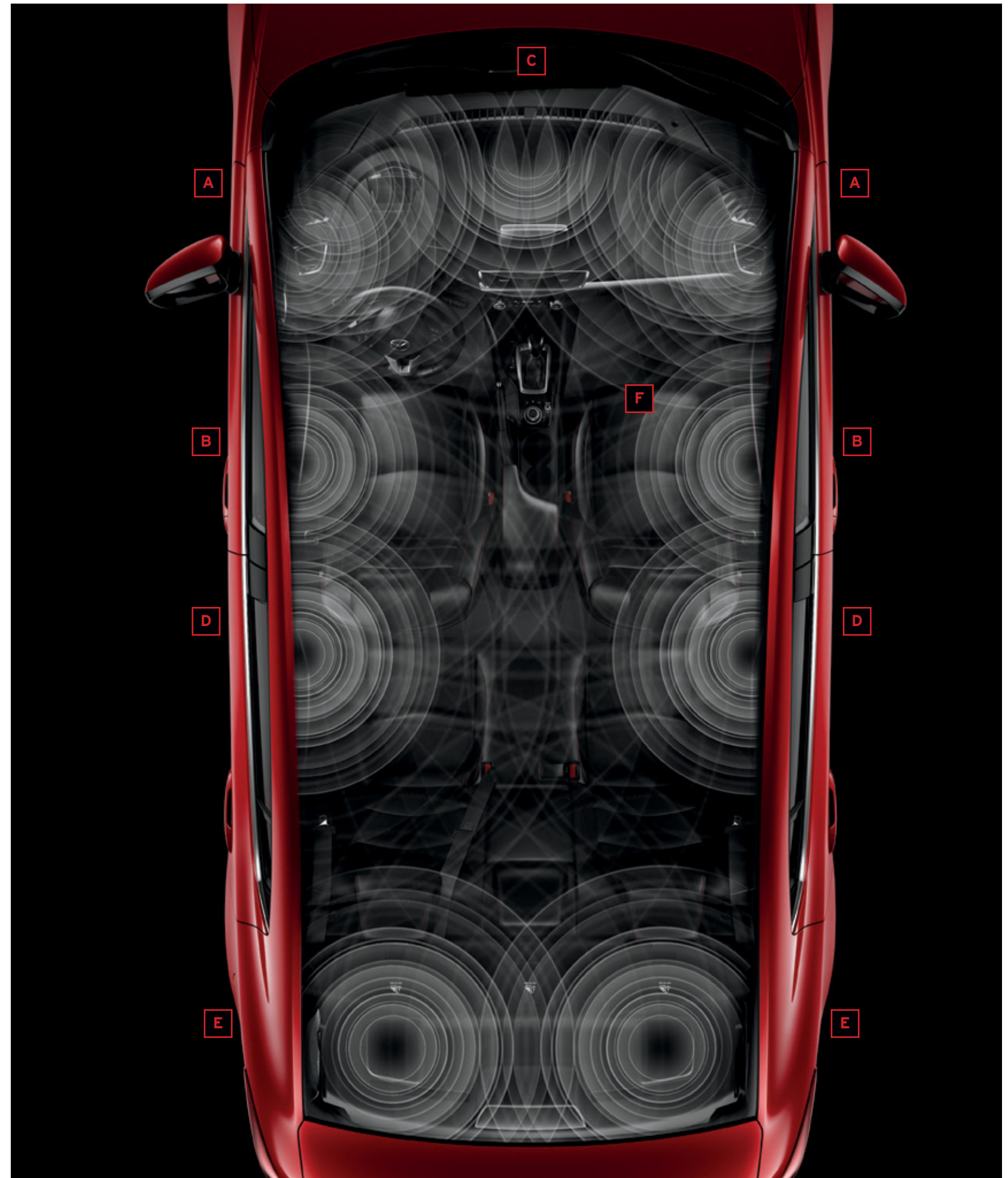

\*SiriusXM Satellite Radio reception requires a subscription and Mazda satellite radio. See full disclaimer in Specifications.

**STORAGE FLEXIBILITY THAT GIVES YOU ROOM TO ROAM.**

With the Mazda3, you can enjoy all the conveniences of a compact car without ever compromising cargo space. With both rear seatbacks folded down, Mazda3 5-Door models offer up to a generous 47.1 cubic feet of storage space. And when you have more passengers than gear, every Mazda3 model offers plenty of versatility. Its 60/40 split fold-down rear seatbacks allow you to either fold down both sections for maximum storage or keep one section up, leaving room for a passenger or child-safety seat.



Mazda3 s Grand Touring 5-Door interior shown in black leather





*A LONG, GRUELING JOURNEY. NOT A SINGLE TRACE OF EVIDENCE.*

After a long drive from Japan through Europe, and then Western Europe, you'd expect to pick up a few souvenirs. You may also expect your car to pick up a little structural damage, considering the bad terrain, weather, potholes and other harsh road conditions. But that was not the case with the Mazda3. At the end of this long journey, our engineers took apart five Mazda3 vehicles, piece by piece, and literally put them under a microscope. The result? Nothing. After examining and photographing over

30,000 parts, they found no significant wear or damage. And out on the test track, no vibrations, rattles or noise from the steering, brakes, body or suspension. So after trekking multiple continents and countries, impressive mountain ranges and country sides, and even some European cobblestoned streets, over thousand upon thousands of miles, our drivers came back with plenty of memories. But not much actual proof of an epic road trip.

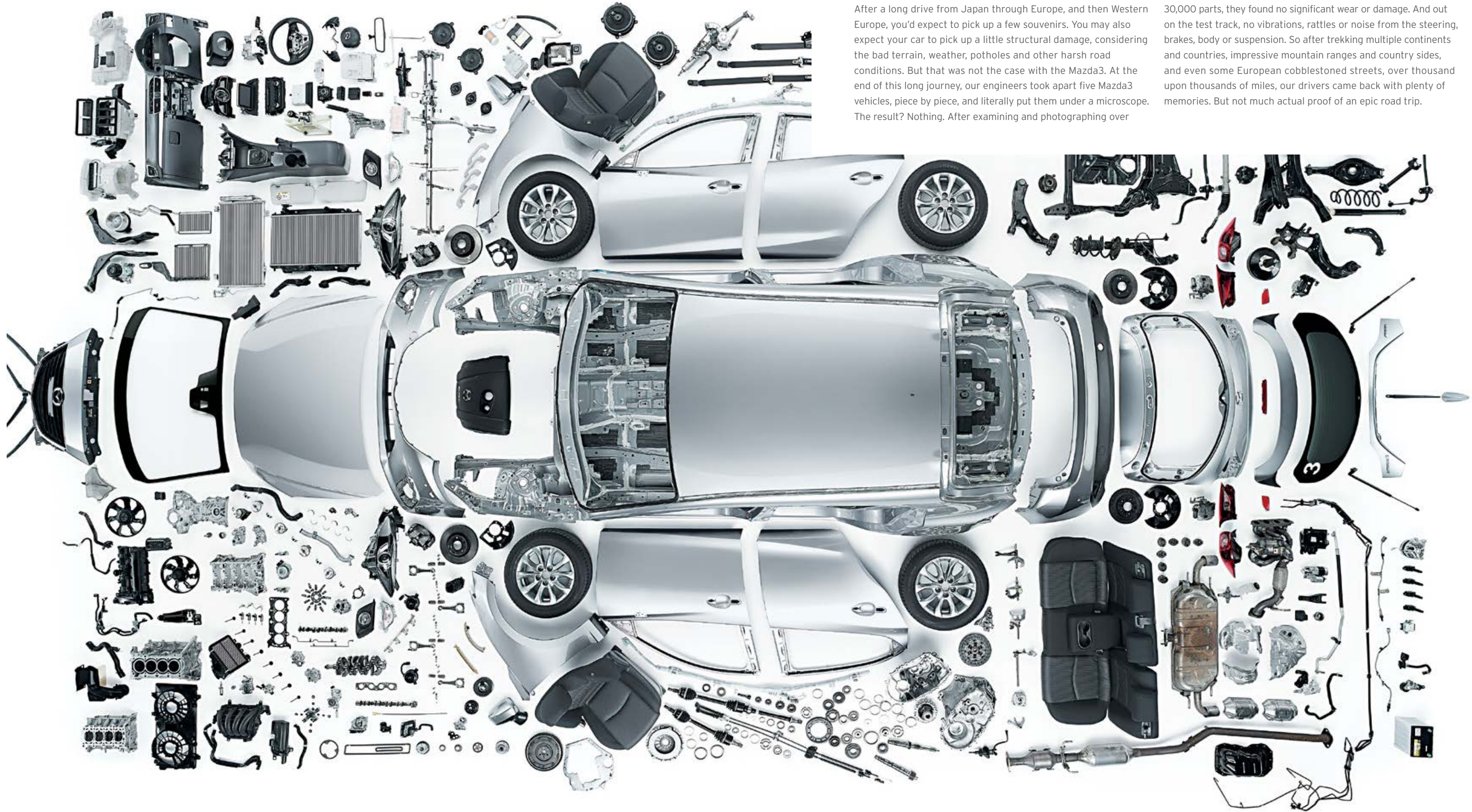



*“The new Mazda3 is a great-looking car that’s inherently engaging from behind the wheel.”*

— Road & Track, July 2013

Mazda3 s Grand Touring 4-Door model shown in Soul Red Metallic

### MAZDA3 COLORS



Soul Red Metallic\*



Meteor Gray Mica

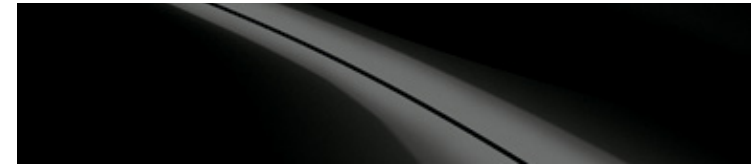

Jet Black Mica

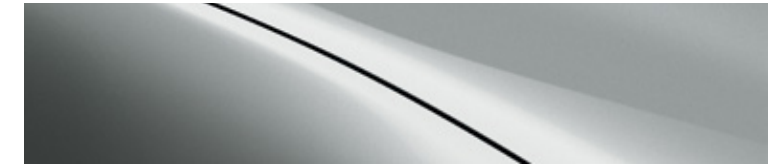

Liquid Silver Metallic

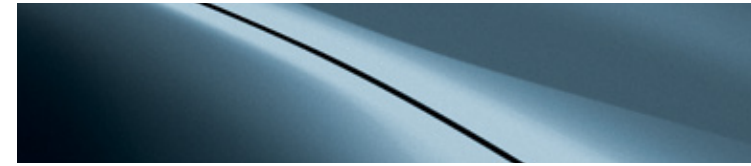

Blue Reflex Mica



Titanium Flash Mica

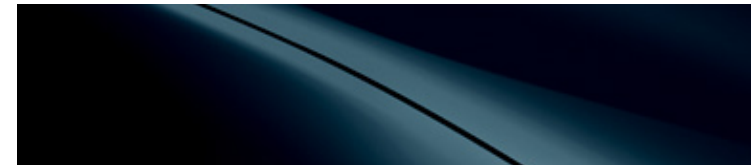

Deep Crystal Blue Mica



Snowflake White Pearl Mica\*

\*Extra cost option.

### MAZDA3 UPHOLSTERY

#### i SPORT

#### i TOURING

#### i GRAND TOURING AND s TOURING

#### s GRAND TOURING

Black Cloth

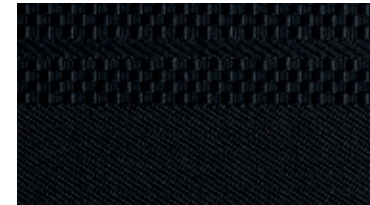

Black Cloth

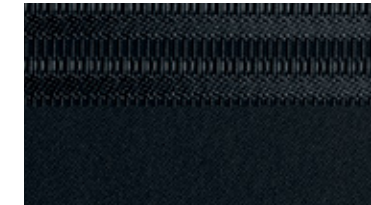

Black Leatherette

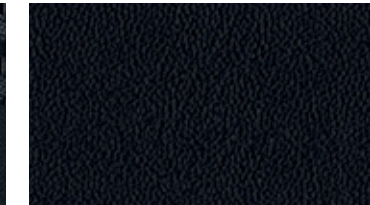

Black Leather

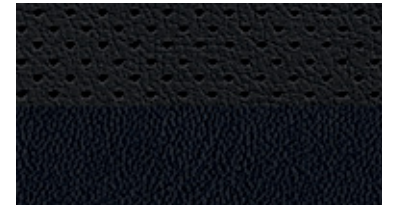

Sand Cloth

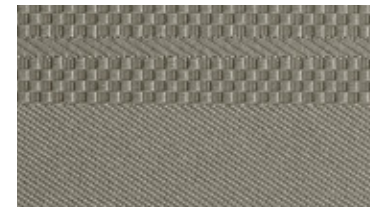

Sand Cloth

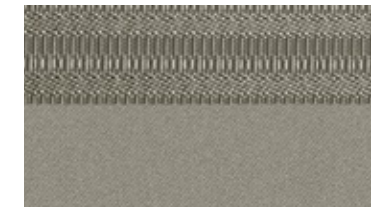

Almond Leather



### MAZDA3 WHEELS

16-inch Wheel Cover



16-inch Alloy



18-inch Alloy



## MAZDA3 SPECIFICATIONS & CAPACITIES

	<b>Mazda3 i</b> 4-Door & 5-Door	<b>Mazda3 s</b> 4-Door & 5-Door
<b>ENGINE</b>		
Engine type	SKYACTIV-G 2.0L DOHC 4-cylinder with VVT	SKYACTIV-G 2.5L DOHC 4-cylinder with VVT
Horsepower	155 hp @ 6,000 rpm	184 hp @ 5,700 rpm
Torque	150 lb-ft @ 4,000 rpm	185 lb-ft @ 3,250 rpm
Redline	6,800 rpm	6,500 rpm
Displacement (cc)	1,998	2,488
Bore x Stroke (mm)	83.5 x 91.2	89.0 x 100.0
Compression Ratio	13.0:1	13.0:1
Fuel System	Advanced direct injection	
Recommended Fuel	Regular unleaded	
Valvetrain	4 valves per cylinder with variable intake valve timing (VVT)	
Ignition System	Direct coil-on-plug electronic ignition with platinum-tipped spark plugs	
Engine Block	Aluminum alloy	
Cylinder Head	Aluminum alloy	
Emission Control Type (Fed/Cal)	Tier2-BIN5 / PZEV	Tier2-BIN5 / ULEV (MT); Tier2-BIN5 / PZEV (AT)
<b>DRIVETRAIN</b>		
Type	Front-wheel drive	
Manual Transmission	SKYACTIV-MT 6-speed	SKYACTIV-MT 6-speed
Automatic Transmission	SKYACTIV-Drive 6-speed with manual-shift mode	SKYACTIV-Drive 6-speed with manual-shift mode and Sport mode
<b>CHASSIS</b>		
Brakes		
– Front / Rear	11.02-inch vented disc / 10.43-inch solid disc	11.61-inch vented disc / 10.43-inch solid disc
– ABS	4-wheel, 4-channel with Electronic Brakeforce Distribution and Brake Assist	
Steering type	Power rack-and-pinion with variable assist	
Power assist	Electric Power Assist Steering	
Overall steering ratio	14:1	
Steering wheel turns, lock-to-lock	2.57	
Turning circle, curb-to-curb (ft)	34.78	
Suspension	4-wheel independent	
– Front / Rear	MacPherson strut with stabilizer bar / Multilink with stabilizer bar	
Wheel size (in)	16 x 6.5	18 x 7.0
Tire size	P205/60 R16 all-season radial	P215/45 R18 all-season radial

### Mazda3 5-Door

#### EXTERIOR DIMENSIONS (INCHES)

Wheelbase	106.3
Track, front	61.2
Track, rear	61.4
Overall Length	175.6
Overall Width	70.7
Overall Height (unladen)	57.3
Minimum ground clearance (laden)	6.1

#### INTERIOR DIMENSIONS (INCHES)

Headroom, front / rear, without moonroof	38.6 / 37.6
Headroom, front / rear, with moonroof	37.6 / 37.5
Legroom, front / rear	42.2 / 35.8
Shoulder room, front / rear	57.2 / 54.4
Hip room, front / rear	55.5 / 53.5

#### WEIGHTS AND CAPACITIES

Curb weight (lb)	
– Mazda3 i models, with MT / AT	2,865 / 2,931
– Mazda3 s models, with MT / AT	2,978 / 3,028
EPA passenger volume (cu ft)	96.4
5-Door cargo volume, rear seats up / down (cu ft)	20.2 / 47.1

#### EPA-ESTIMATED FUEL ECONOMY (CITY/HIGHWAY MPG)<sup>1</sup>

Mazda3 i models, with MT / AT	29 / 40 ; 30 / 40
Mazda3 s models, with MT / AT	26 / 35 ; 27 / 37
Mazda3 s models, AT with i-ELOOP	28 / 39
Fuel tank capacity (U.S. gallons)	13.2

### Mazda3 4-Door

#### EXTERIOR DIMENSIONS (INCHES)

Wheelbase	106.3
Track, front	61.2
Track, rear	61.4
Overall Length	180.3
Overall Width	70.7
Overall Height (unladen)	57.3
Minimum ground clearance (laden)	6.1

#### INTERIOR DIMENSIONS (INCHES)

Headroom, front / rear, without moonroof	38.6 / 37.6
Headroom, front / rear, with moonroof	37.6 / 37.5
Legroom, front / rear	42.2 / 35.8
Shoulder room, front / rear	57.2 / 54.4
Hip room, front / rear	55.5 / 53.5

#### WEIGHTS AND CAPACITIES

Curb weight (lb)	
– Mazda3 i models, with MT / AT	2,869 / 2,931
– Mazda3 s models, with MT / AT	2,947 / 3,001
EPA passenger volume (cu ft)	96.3
4-Door trunk volume (cu ft)	12.4

#### EPA-ESTIMATED FUEL ECONOMY (CITY/HIGHWAY MPG)<sup>1</sup>

Mazda3 i models, with MT / AT	29 / 41 ; 30 / 41
Mazda3 s models, with MT / AT	25 / 37 ; 28 / 39
Mazda3 s models, AT with i-ELOOP	29 / 40
Fuel tank capacity (U.S. gallons)	13.2

## MAZDA3 i SPORT 4-DOOR + 5-DOOR

Includes the following features:



4-Door



5-Door

#### DRIVETRAIN

SKYACTIV-G 2.0L gasoline engine  
SKYACTIV-MT 6-speed manual  
or available SKYACTIV-Drive 6-speed automatic transmission

#### EXTERIOR

Body-colored dual folding power side mirrors  
Body-colored bumpers  
Body-colored door handles  
Clear-lens halogen headlights  
Daytime running lights  
Dual exhaust outlets  
Integrated high-mount center brake light  
Rear window wiper (5-Door only)  
Rear roof spoiler (5-Door only)  
Bright exhaust tips (5-Door only)  
16-inch steel wheels with full wheel covers  
P205 / 60 R16 all-season tires

#### SAFETY AND SECURITY

3-point seat belts for all seating positions  
Front seat-belt pretensioners with force limiters  
Advanced front air bags, front side-impact air bags and side-impact air curtains<sup>2</sup>  
Whiplash-reducing front seat headrests  
Child-safety rear door locks  
Collapsible steering column  
Engine-immobilizer anti-theft system  
E911 automatic emergency notification  
Front and rear side-impact door beams  
LATCH rear seat child safety-seat-anchors and upper tethers  
Tire-Pressure Monitoring System  
SKYACTIV-Body with Ring Structure  
Dynamic Stability Control<sup>3</sup> and Traction Control System

#### INTERIOR

5-passenger seating capacity  
Air conditioning with pollen filter  
Power door locks with 2-stage unlocking feature  
Power windows with driver's-one-touch up/down  
Push Button Start  
Remote keyless entry system with retractable key  
Rearview camera<sup>6</sup>  
AM/FM audio system with 6 speakers  
Bluetooth® hands-free phone and audio streaming  
MAZDA CONNECT™ Infotainment system<sup>4</sup> with:  
– 7-inch full-color touch-screen display  
– Multifunction Commander control  
– Infotainment system voice command  
– HD Radio  
– Aha™ internet radio integration  
– Pandora® internet radio integration  
– Stitcher™ internet radio integration  
– Radio Broadcast Data System program information  
– SMS text message audio delivery and reply  
Cruise control  
Auxiliary-audio input jack  
Dual USB audio input ports  
Steering-wheel-mounted audio and cruise controls

#### INTERIOR (continued)

Tilt and telescopic steering column  
60/40 split fold-down rear seatbacks  
12V power outlet  
Center console armrest with covered storage compartment  
Driver's and front-passenger's covered visor vanity mirror  
Front-door storage pockets with bottle holders  
Front-passenger's seatback pocket  
Manual driver's seat height adjuster  
Rear-door bottle holders  
Rear window defogger  
Cloth-trimmed sport seats  
Cloth-trimmed door panel inserts  
Dual front map lights  
Remote hood and fuel door releases  
Tachometer  
Dual trip odometers  
Trip computer  
Carpeted floor mats

#### PACKAGES

**Sport Preferred Equipment Package** includes 16-inch alloy wheels, bright beltline trim, body-colored dual folding heated power side mirrors with integrated turn signal lamps, premium cloth-trimmed sport seats, rear seat center arm rest, auto on/off headlights, rain-sensing windshield wipers and Blind Spot Monitoring with Rear Cross Traffic Alert<sup>5</sup>

#### BLACK CLOTH

#### EXTERIOR COLORS



#### SAND CLOTH

#### EXTERIOR COLORS



#### 16-INCH WHEEL COVER



## MAZDA3 i TOURING 4-DOOR + 5-DOOR

Includes the following features in addition to or in place of the i Sport:



4-Door



5-Door

### EXTERIOR

- 16-inch alloy wheels
- Power sliding-glass moonroof with one-touch open
- Body-colored dual folding heated power side mirrors with integrated turn signal lamps
- Rear deck lip spoiler (4-Door models)
- Bright beltline trim
- Auto on/off headlights
- Halogen fog lights
- Rain-sensing windshield wipers

### SAFETY

- Blind Spot Monitoring with Rear Cross Traffic Alert<sup>5</sup>

### INTERIOR

- Mazda Advanced Keyless Entry
- Premium cloth-trimmed sport seats
- Leather-wrapped steering wheel with red stitching
- Leather-wrapped parking brake handle with red stitching
- Leather-wrapped shift knob with red stitching
- Rear-seat center armrest with cupholders
- Sunglasses holder
- Illuminated driver and front-passenger vanity mirrors

### PACKAGES

**Touring Popular Equipment Package** includes Bose® 9-speaker Surround Sound system with Centerpoint® 2 and AudioPilot® 2, SiriusXM Satellite Radio with 4-month subscription to the Sirius All Access package,<sup>7</sup> CD player, dual-zone automatic climate control system, auto-dimming rearview mirror and roof-mounted shark fin antenna

#### BLACK CLOTH EXTERIOR COLORS

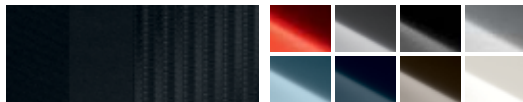

#### SAND CLOTH EXTERIOR COLORS



#### 16-INCH ALLOY WHEEL



<sup>1</sup>EPA-estimated mileage. Actual results will vary. <sup>2</sup>Always wear your seat belt and secure children in the rear seat in appropriate child restraints. <sup>3</sup>Dynamic Stability Control (DSC) is an electronic system designed to help the driver maintain control under adverse conditions. It is not a substitute for safe driving practices. Factors including speed, road conditions and driver steering input can all affect whether DSC will be effective in preventing loss of control. Please see your owner's manual for further details. <sup>4</sup>Don't drive while distracted. Even with voice commands, only use MAZDA CONNECT™ / other devices when safe. Some features may be locked out while the vehicle is in gear. Not all features are compatible with all phones. Message and data rates may apply. <sup>5</sup>Always check your mirrors. Be aware of the traffic around you. <sup>6</sup>Rearview camera does not provide a comprehensive view of the entire rear area of this vehicle. Always check your surroundings. <sup>7</sup>SiriusXM Satellite Radio reception requires a subscription and Mazda satellite radio. Subscriptions to SiriusXM services are sold by SiriusXM after a 4-month trial subscription to the Sirius All Access package expires and are continuous until you call SiriusXM at 1-866-635-2349 to cancel. See SiriusXM Customer Agreement for complete terms at [www.siriusxm.com](http://www.siriusxm.com). Sirius satellite service available only to those at least 18 and older in the 48 contiguous USA, DC, and P.R. (with coverage limitations). Sirius, XM and all related marks and logos are trademarks of Sirius XM Radio Inc. <sup>8</sup>Lane Departure Warning System, Forward Obstruction Warning and Mazda Radar Cruise Control are not substitutes for safe and attentive driving. There are limitations to the range and detection of the systems. Please see your owner's manual for further details. <sup>9</sup>Smart City Brake Support operates under certain low-speed conditions between about 2 and 18 mph. It is not a substitute for safe and attentive driving. Factors including movement and shape of the object in front of the vehicle, weather and road conditions can all impact automatic stopping. SKYACTIV is a registered trademark of Mazda Motor Corporation. Bluetooth is a registered trademark of Bluetooth SIG, Inc.

## MAZDA3 i GRAND TOURING 4-DOOR + 5-DOOR

Includes the following features in addition to or in place of the i Touring:



4-Door



5-Door

### EXTERIOR

- Roof-mounted shark fin antenna

### INTERIOR

- Dual-zone automatic climate control system
- 8-way power-adjustable driver's seat
- Variable heated front seats
- Leatherette-trimmed sport seats
- Leatherette-trimmed door panel inserts
- Mazda navigation system
- Bose® 9-speaker Surround Sound system with Centerpoint® 2 and AudioPilot® 2
- SiriusXM Satellite Radio with 4-month subscription to the Sirius All Access package<sup>7</sup>
- CD player
- Auto-dimming rearview mirror

#### BLACK LEATHERETTE EXTERIOR COLORS



#### 16-INCH ALLOY WHEEL



## MAZDA3 s TOURING 4-DOOR + 5-DOOR

Includes the following features in addition to or in place of the i Grand Touring:



4-Door



5-Door

### ENGINE

- SKYACTIV-G 2.5L gasoline engine
- SKYACTIV-Drive 6-speed automatic transmission with Sport mode
- Steering-wheel-mounted paddle shifters

### EXTERIOR

- 18-inch alloy wheels
- P215/45 R18 all-season tires
- Gloss black front grille

### INTERIOR

- Active Driving Display

#### BLACK LEATHERETTE EXTERIOR COLORS



#### 18-INCH ALLOY WHEEL



## MAZDA3 s GRAND TOURING 4-DOOR + 5-DOOR

Includes the following features in addition to or in place of the s Touring:



4-Door



5-Door

### TRANSMISSION

- SKYACTIV-MT 6-speed manual or available SKYACTIV-Drive 6-speed automatic transmission with Sport mode

### EXTERIOR

- LED daytime running lights
- Bi-Xenon headlights with auto leveling
- Adaptive Front-lighting System
- LED combination taillights

### INTERIOR

- Auto-dimming rearview mirror with HomeLink®
- Perforated leather-trimmed sport seats

### PACKAGES

**Grand Touring Technology Package** includes i-ELOOP regenerative engine braking system, active grille shutters, High Beam Control, Lane Departure Warning System,<sup>8</sup> Forward Obstruction Warning,<sup>8</sup> Smart City Brake Support<sup>9</sup> and Mazda Radar Cruise Control<sup>8</sup>

#### BLACK LEATHER EXTERIOR COLORS



#### ALMOND LEATHER EXTERIOR COLORS

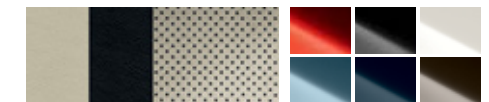

#### 18-INCH ALLOY WHEEL



## WE'RE COMMITTED TO OUR DRIVERS.

Every new 2016 Mazda3 is protected by a:

- 3-year/36,000-mile<sup>1</sup> New-Vehicle Limited Warranty
- 3-year/36,000-mile<sup>1</sup> 24/7 Emergency Roadside Assistance program
- 5-year/60,000-mile<sup>1</sup> Powertrain Limited Warranty
- 5-year/unlimited-mileage Warranty Against Body Rust-Through (Anti-Perforation Limited Warranty)

<sup>1</sup>Whichever comes first.



Even after your vehicle warranty has expired, Mazda Extended Confidence provides nearly all the same parts and components covered under your New-Vehicle Limited Warranty. Accepted nationwide and utilizing only Mazda Genuine Parts (where available), Mazda Extended Confidence gives you peace of mind for miles beyond your expectations.

## FINANCING WITHOUT THE FUSS.



Whether you're buying or leasing a new Mazda, Certified Pre-Owned Mazda or a used vehicle, Mazda Capital Services<sup>2</sup> can help make the financing process more convenient and satisfying. One of the largest auto lenders in America, Mazda Capital Services is known for first-class customer service, a wide range of financing options and highly competitive rates.

To find out which purchase or lease plan is right for you, talk with your Mazda Dealer or visit [MazdaUSA.com](http://MazdaUSA.com).

<sup>2</sup>The tradename "Mazda Capital Services," as well as the Mazda and Mazda Capital Services logos, are owned by Mazda Motor Corporation or its affiliates and are licensed to JPMorgan Chase Bank, N.A. ("Chase"). Retail/loan and lease accounts are owned by Chase.

FOR DETAILS, PLEASE SEE YOUR MAZDA DEALER, VISIT [MAZDAUSA.COM](http://MAZDAUSA.COM) OR CALL TOLL-FREE (800) 639-1000.

# MAZDA3 ACCESSORIES. IT'S YOUR MAZDA—MAKE IT YOUR OWN.

## 01 // 18-INCH FORGED RAYS WHEELS WITH DIAMOND EDGE /

Made by RAYS, these 18-inch Gloss Black Forged Wheels give your Mazda3 added style to match its sleek exterior design.



## 02 // 18-INCH DARK ALLOY WHEELS /

Bring out the Mazda3's dark side with these 18-inch Dark Alloy Wheels.

## 03 // AERO KIT /

Give your Mazda3 a bold, aerodynamic stance. Accessorize your ride with our Brilliant Black Aero Kit that includes Door Mirror Caps, Front Air Dam, Side Sills, Rear Diffuser and body-colored Rear Spoiler. Pick and choose only the accessories you like, or go all-out and deck your drive with all five.



## 04 // CARGO TRAY<sup>1</sup> /

Life doesn't have to be messy, at least not inside your Mazda3. This flexible, durable Cargo Tray protects against spills and other damage. Removes easily for quick cleanup.

<sup>1</sup>Please remember to properly secure all cargo.



## 05 // ALL-WEATHER FLOOR MATS /

Fitted perfectly to your Mazda3, these All-Weather Floor Mats guard against water, sand, mud, snow or whatever you drag through the door.

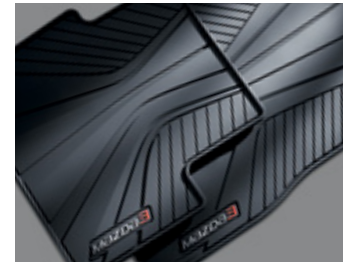

## 06 // REAR BUMPER GUARD /

Tailored and sleek, our durable stainless steel Rear Bumper Guard not only looks great, but helps protect the rear bumper from chips and scratches.



## 07 // NAVIGATION SYSTEM /

This convenient system integrates with your car's display screen to offer advanced lane guidance and a 3D interactive map. Plus, it can be controlled by voice commands.



## 08 // MAZDA MOBILE START<sup>2,3</sup> /

Did you lock your car or not? Know for sure with the convenience of our smartphone-controlled Mazda Mobile Start App. Lock or unlock your doors, start the engine, turn the rear defroster on or use the Carfinder function from just about anywhere. One-year subscription included. Visit [MazdaMobileStart.com](http://MazdaMobileStart.com).



<sup>2</sup>One-year subscription included. Continuation is \$65 per year. App available on iPhone<sup>®</sup> and Android<sup>™</sup> phones. Check [www.mazdamobilestart.com](http://www.mazdamobilestart.com) for compatibility. Not compatible with all phones and carriers. Message and data rates may apply. iPhone is a registered trademark of Apple Inc. Android is a trademark of Google Inc. <sup>3</sup>Late Availability.

For a full list of Genuine Mazda Accessories for your Mazda3, please visit: [accessories.MazdaUSA.com](http://accessories.MazdaUSA.com)



 **MAZDA**  
**DRIVE FOR GOOD**

Last year during our Mazda Drive for Good® charitable program, our Mazda Dealers and partners raised millions of dollars for a number of national and local charities. But what's even more significant is that collectively, we pledged more than 66,000 hours of volunteer time to local and national organizations across the country. Our Mazda Dealers have a long history of giving back both time and money to their own communities. And their efforts truly define our Mazda values.

Mazda Drive for Good® is just one of the many charitable programs that has allowed Mazda to donate millions to worthy causes across the United States since 1992.

Because giving back is the Mazda Way.



*WE KNOW YOUR FIRST  
IMPRESSION OF MAZDA  
STARTS WITH US,  
YOUR MAZDA DEALER.*

It's a responsibility we don't take lightly.

It's why we work hard every day to make sure your customer service experience exceeds your expectations, in every way.

From the factory to your first test drive,

and to every drive you'll ever make in a Mazda,

we're here because driving matters.



MazdaUSA.com



© 2015 Mazda Motor of America, Inc. • 7755 Irvine Center Drive, Irvine, CA 92618 • (800) 639-1000 • Correct at time of printing. Printed in U.S.A. 7/15 (100K)  
Part no. 9999-92-M3-16

**PRODUCT CHANGES AND OPTIONS AVAILABILITY:** Following publication of this brochure, certain changes in standard equipment, options, prices and the like-or product delays-may have occurred which would not be included in these pages. Your Mazda Dealer is your best source for up-to-date information. Mazda reserves the right to change product specifications at any time without incurring obligations. Options shown or described in this brochure are available at extra cost and may be offered only in combination with other options or subject to additional ordering requirements or limitations.



DRIVING MATTERS™

*ZOOM-ZOOM*